

ZAKŁAD IZOLATORÓW ELEKTROTECHNICZNYCH  
BOPLAST Sp. z o.o.

Adres:

ul. B.Krzywoustego 1,  
tel. +48 59 862 01 86;  
www.boplast.pl

84-300 Lębork  
tel. 516 198 886  
e-mail: boplast@boplast.pl

POST INSULATORS \* BUSHING INSULATORS \* INSULATION PRODUCTS \* SERVICES

## Bushing insulator 12 kV type SPWSGc 25-12/4,0

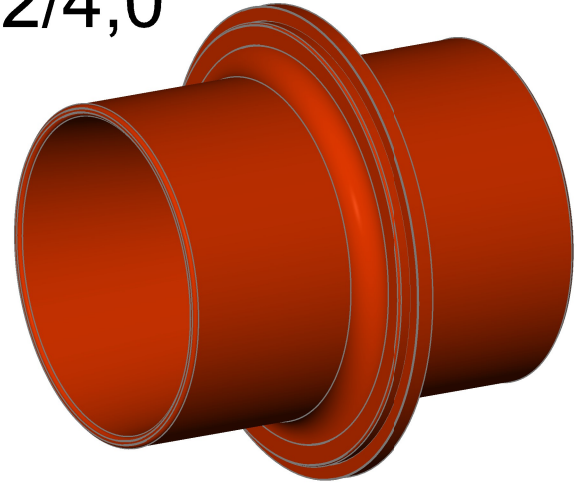
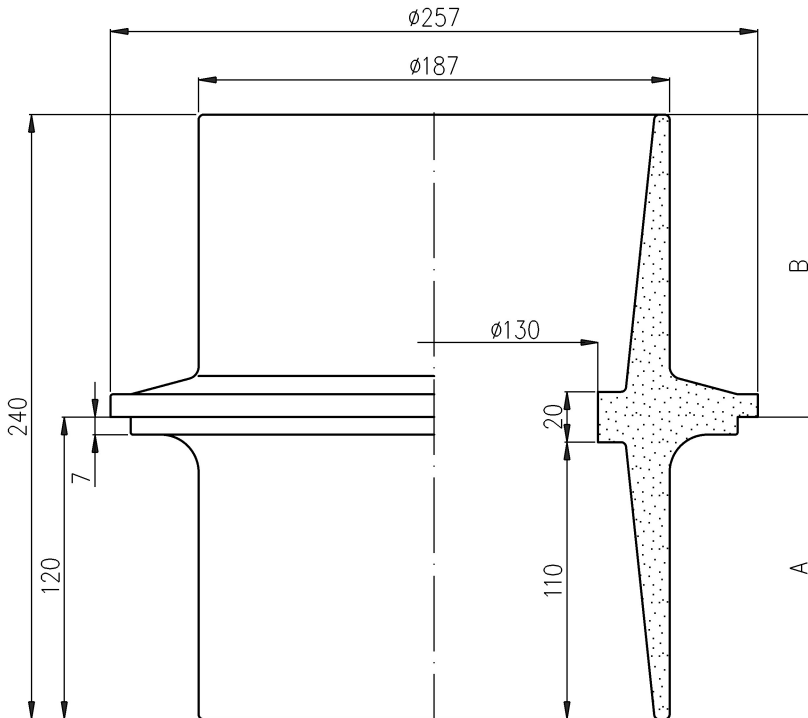

1. Insulator material: epoxy compound
2. Voltage, temperature and short circuit requirements according to PN-EN 60137
3. Indoor insulator

Mounting hole minimum diameter should be 242mm

Rated insulation voltage	12 kV
Lightning impulse withstand voltage	75 kV
Dry withstand alternate voltage (50Hz, 1 min)	28 kV
Rated current	4000 A
Bending strength Po	25 kN
Creepage distance	A 149 mm
	B 148 mm
Weight	4,0 kg

1. Insulator is mounted to subsoil (wall, partition) using three bushings and M12 screws.
2. Bushings are included in the package.
3. Centricity of current rails in relation to the opening of insulator provide upper and lower inserts. The inserts are fitted to insulator using two M6 screws.
4. Inserts, M6 and M12 screws are not included in the package.
5. Inserts are made according to client's specified requirements.

### Insulator assembly diagram

