

ZAKŁAD IZOLATORÓW ELEKTROTECHNICZNYCH
BOPLAST Sp. z o.o.

Adres:

ul. B.Krzywoustego 1,
tel. +48 59 862 01 86;
www.boplast.pl

84-300 Lębork
tel. 516 198 886
e-mail: boplast@boplast.pl

IZOLATORY WSPORCZE * IZOLATORY PRZEPUSTOWE * WYROBY IZOLACYJNE * USŁUGI

Post insulator 12 kV type JO16-75.bp5

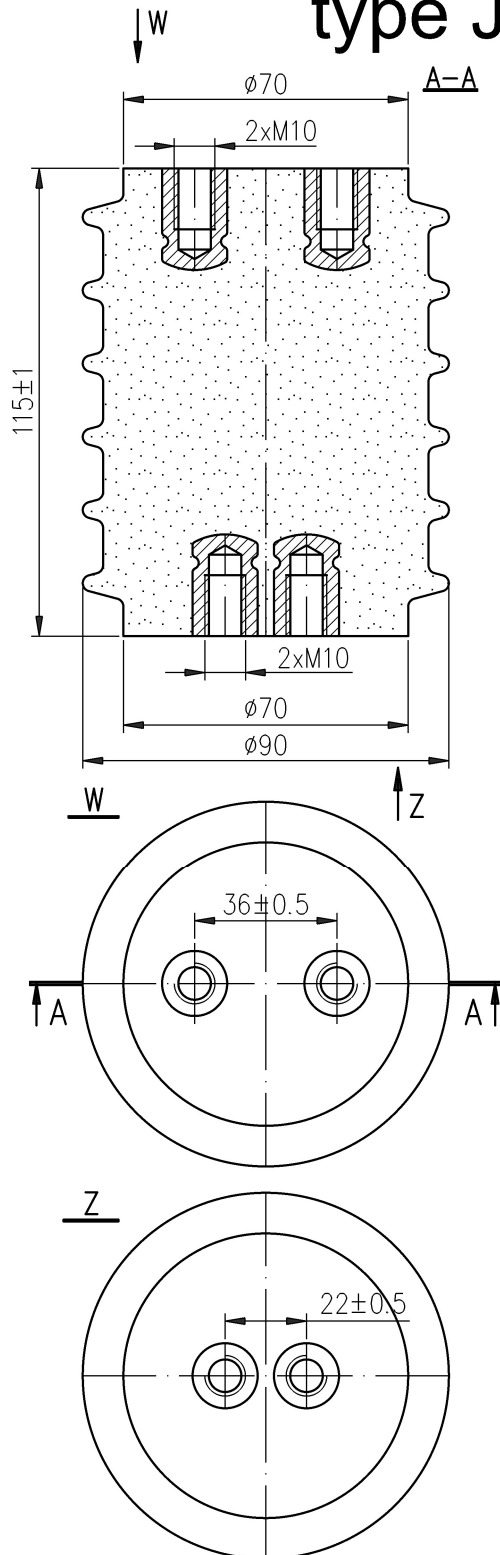

1. Insulator material:
epoxy compound
2. Parameters according to PN-IEC 60273
3. Tested according to PN-EN 60660
4. Max screw tightening torque:
- M10 - 30 Nm
5. Indoor insulator

Rated insulation voltage	12 kV
Lighting impulse withstand voltage	75 kV
Dry withstand alternate voltage (50Hz, 1 min)	38 kV
Bending strength	16 kN
Creepage distance	158 mm
Weight	1,2 kg

Possible to make screws according to client's requirements.